

HONDA

운전하시기 전에 반드시 이 사용설명서를 읽어주십시오.

사용설명서

CBR954RR



" ' "

가

-
-
-
-

: 954cm³ (cc)

가

2

가

가

CBR954RR(SC50) : 2002 가

*

가

*

*

▲ 경 고

가

가

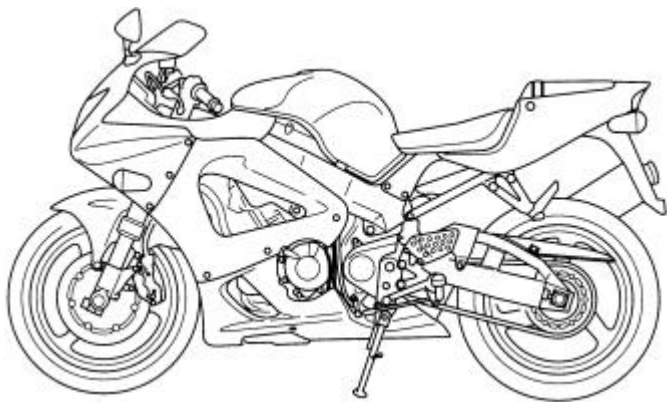

(Honda Motor Cycle Korea Co., Ltd.)



가

.

가

.

.

가

가 ,

.

가

.

•

-

•

-



가

가

.

▲ 위험

▲ 경고

▲ 주의

가

가

- ? (Important Safety Reminders) (Important Safety Reminders)
- ? (Motor Cycle Safety)
- -

	(HISS).....	54
	57
	58
.....		1
.....		1
.....		2
.....		4
.....		8
.....		11
(.....)		28
.....		28
.....		34
.....		37
.....		39
.....		41
.....		44
.....		45
.....		51
.....		51
.....		52
(.....)		59
.....		59
.....		60
.....		62
.....		63
.....		63
U.....		64
.....		65
.....		66
.....		67
.....		68
.....		69
.....		69
.....		71
.....		72
.....		74
.....		75
.....		77

.....	78
.....	79
.....	80
.....	80
.....	81
.....	82
.....	83
1	83
.....	84
.....	85
.....	85
.....	86
.....	89
.....	90
.....	91
.....	92
.....	93
.....	97

.....	102
.....	103
.....	104
.....	105
.....	111
.....	112
.....	113
.....	114
.....	119
.....	121
.....	123
.....	126
.....	127
.....	133
가	137
.....	139
.....	140

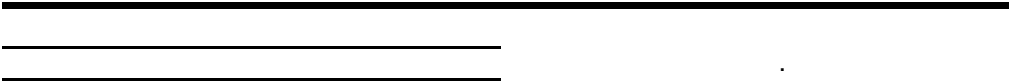

가

가

가

가

(3).

가

가

 경고

가

4

가

가

가

가

가

가

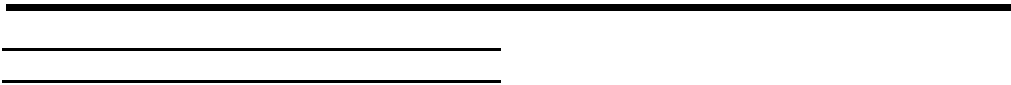

가

가

가

가

가

가

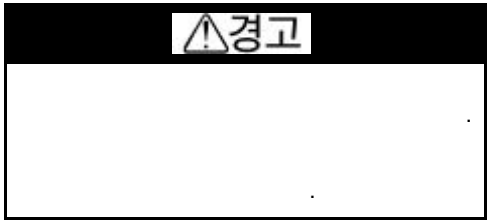

가
130 km/h

189 kg

가

가

•

14 kg

•

(28)

(31)

•

가

가

•

가

•

6

가

 경고

•

가 가 가
가 , ,

•

가 (143). 가



•

, , 가

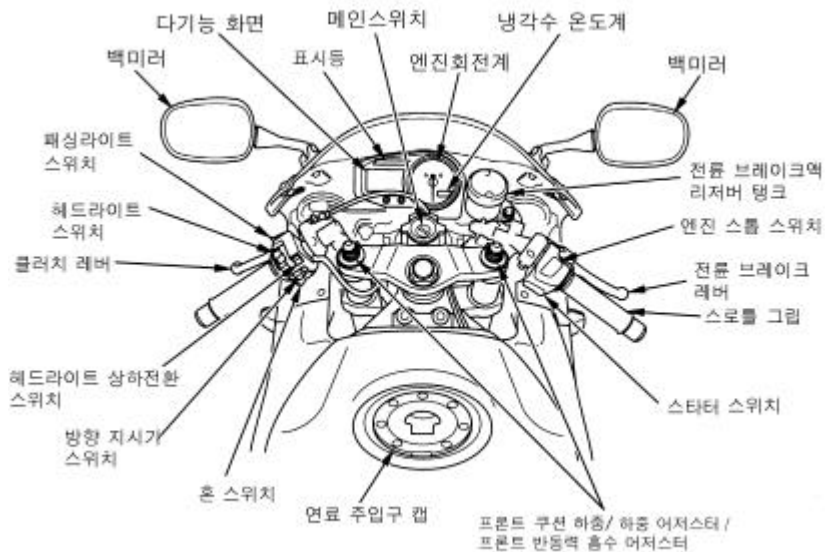

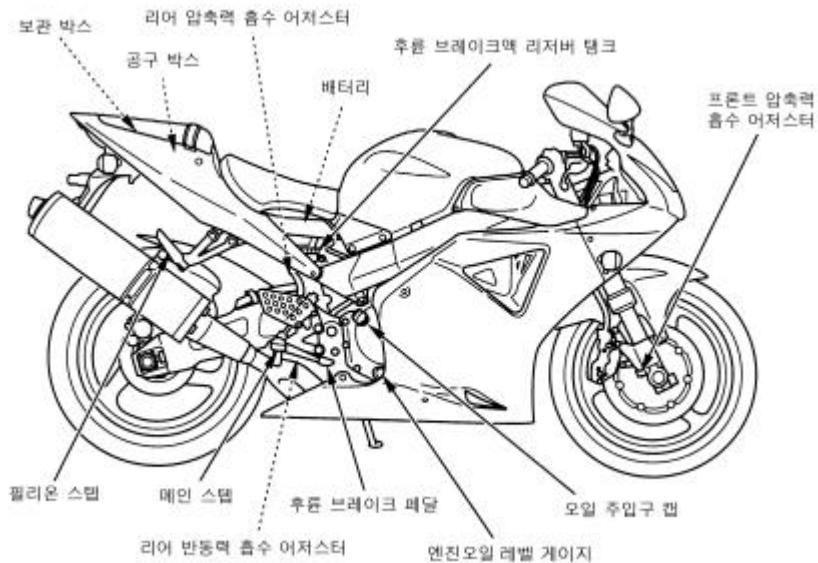

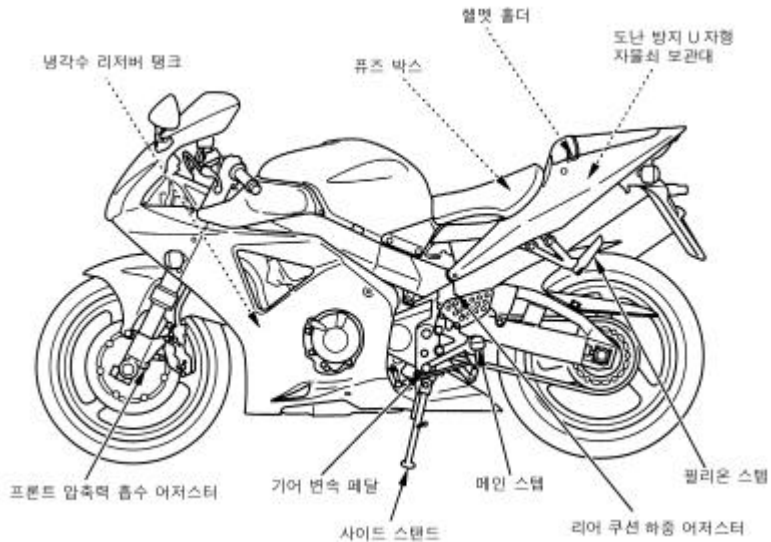

- (1)
- (2)
- (3)
- (4)
- (5)
- (6)
- (7)
- (8)
- (9)
- (10)
- (11)
- (12)
- (13)

(HISS)

()

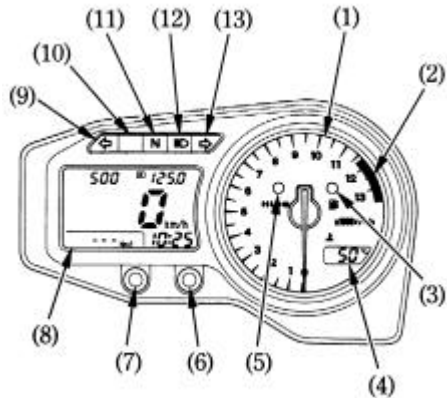

()	
(1) ()	rpm
(2)	<div data-bbox="462 381 585 433" style="border: 1px solid black; width: 60px; height: 25px; margin-bottom: 5px;"></div> * ()
(3)	3.5

()	
(4)	(27). (18).
(5) (HISS) ()	ON 가 (RUN) 가 (54). (HISS) 가 24 (55).

()	
(6)	<p>.</p> <ul style="list-style-type: none"> • • (HISS) • • (), (), () ,
(7)	<p>.</p> <ul style="list-style-type: none"> • • (HISS) • A B •

()	
(8)	(18).
/ / PGM - FI	, PGM-FI() , PGM- FI (20-22).
()	(23).
	(23).
	(23).
	15 (24).
	(25).

()	
(9) ()	가 .
(10) ()	가 , PGM-FI() . 가 ON , 가 (22).
(11) ()	가 .

()	
(12) ()	가 () .
(13) ()	가 .

ON (1)
 (2)
 (8) (9)

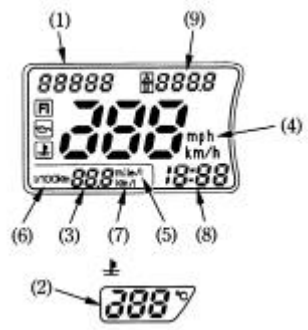

- (1)
- (2)
- (3)
- (4) "mph"
- (5) "mile/l"
- (6) "l/100km"
- (7) "km/l"
- (8)
- (9)

(1)

PGM-FI

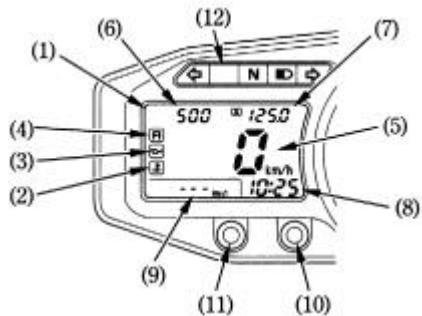

(1)

(3)

(5)

(7)

(9)

(11)

(2)

(4) PGM - FI

(6)

(8)

(10)

(12)

(1)

ON

(2)

가



*

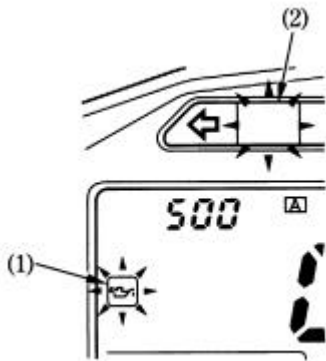

(1)

(2)

가
(1)

(2)

. 39~40

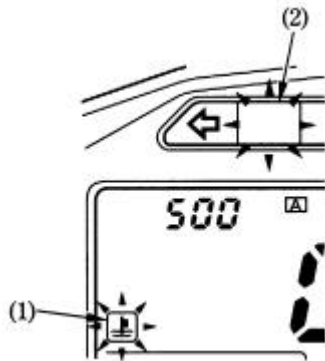

(1)
(2)

PGM - FI

PGM-FI()

PGM-FI (1)

(2)가

ON

(RUN)

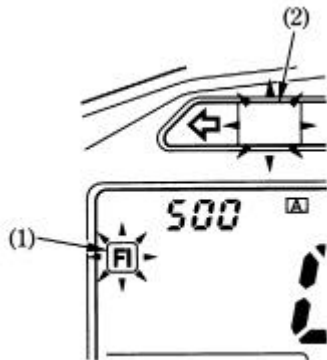

(1) PGM-FI

(2)

/ / /

/ , / ,

()

()

()

A(5)
(7)

B(6)

가

A

B

A

B가

가

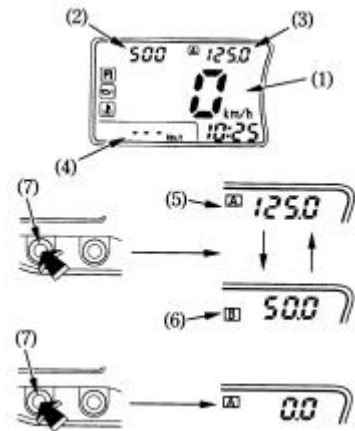

- (1)
- (2)
- (3)

- (4)
- (5)
- (6)
- (7)

A
B

15

가 10km/h “ - -“가

가

(/)

가

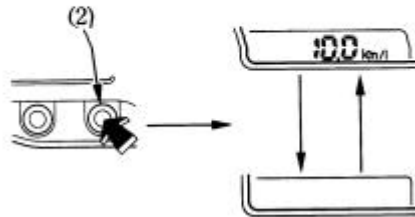

(1)

(2)

1. ON
2. (2)
- (3) 가

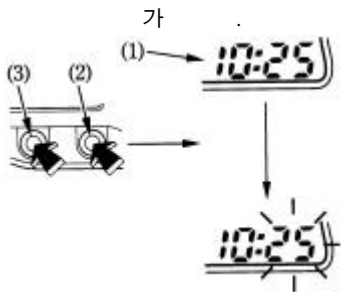

- (1)
- (2)
- (3)

3.

가

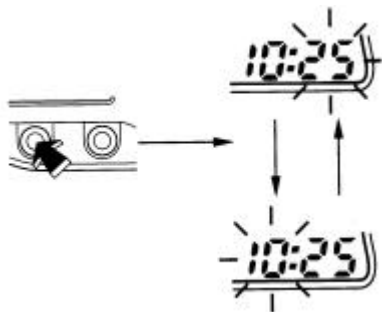

AM/PM

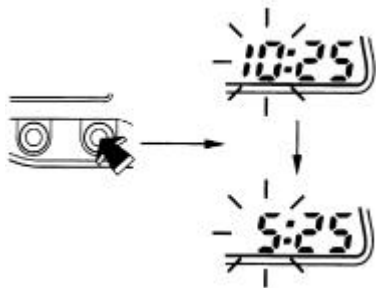

4.

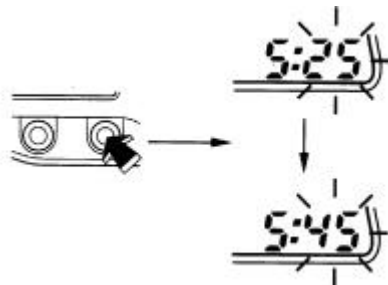

10

가

OFF

(HISS)

“00” “60”

(1)

가 122

가

(2)가

(3)

. 39~40

35	“-“가
35 132	가
132	132

가



*

가

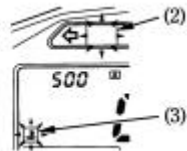
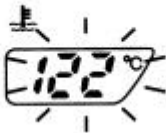

(1)

(2)

(3)

()

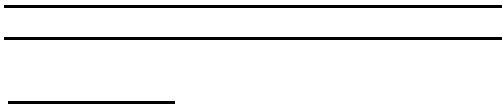

22 mm
(1)

(fork leg) 가

(SOFT)

가

SOFT

가

(HARD)

HARD

1.

(1)

가

()

가 (hard)

2. 가 7

가

3.

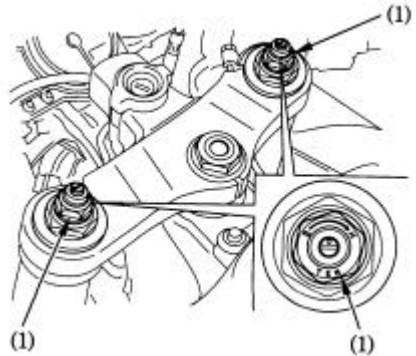

(1)

가 (SOFT)
 가 SOFT
 가 (HARD)
 HARD
 1. (1) 가
 (가)
 (hard)
 2. 가 2
 가
 3.

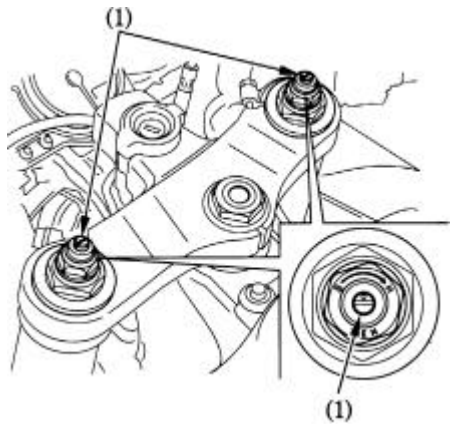

(1)

()

(SOFT)
가
SOFT
가 (HARD)
HARD

1. (1) 가
()
(hard)
2. 가 2
(2)가 (3)
가

3. (1)
(2)
(3)

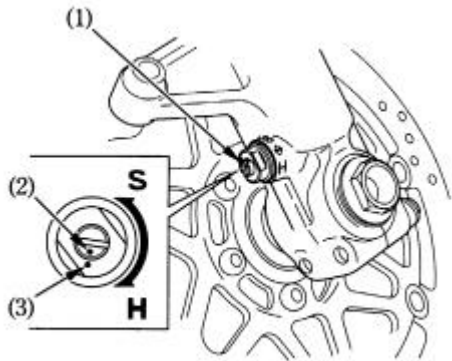

가 (SOFT)
 가 SOFT
 가 (HARD)
 HARD

1. (1) 가
 (가)
 가 (hard)

2. 가 2
 (2)가 (3)
 가

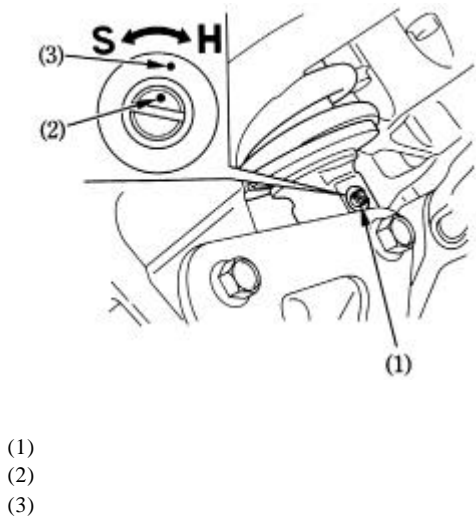

()

가 (SOFT)
가 SOFT
가 (HARD)
HARD

1. (1) 가
()
가 (hard)

2. 가 2
(2)가 (3)
가

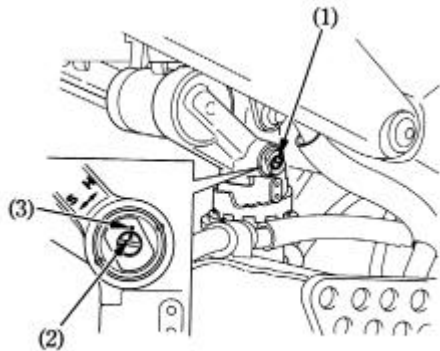

(1)
(2)
(3)

가 . (1) 9
 (2) (3)
 1 3 가
 5 9 4 가
 가 가 가
 가 , ,

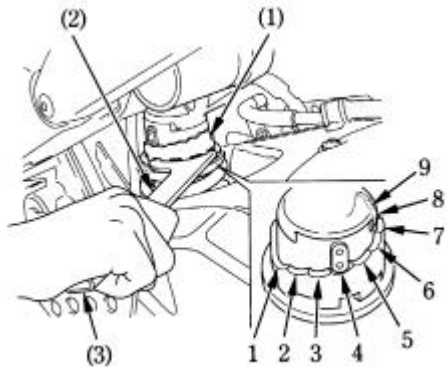

- (1)
- (2)
- (3)

()

가

DOT 4

(119)

가

가

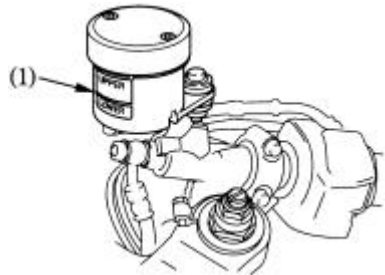

(LOWER) (1)

(1)

(1)

(LOWER)

(119).

가

(1)

(3)

(2)

(4)

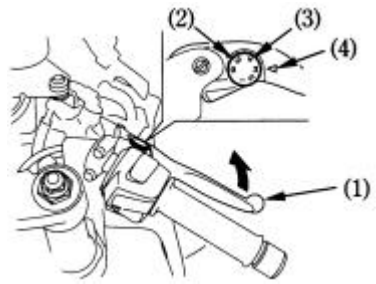

(1)
(2)

(3)
(4)

()

(LOWER)(2)

(UPPER)(1)

(LOWER)(2)

(119)

가

DOT 4

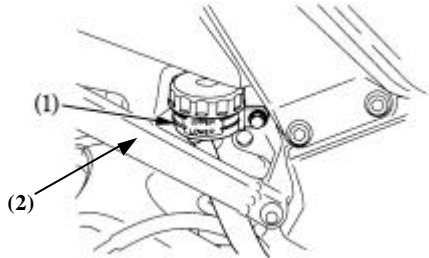

(1) (UPPER)

(2) (LOWER)

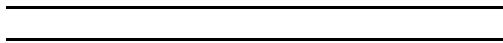

1. (2)

2. 가

가

가

(2)

가

(1)

(2)

10 ~ 20 mm

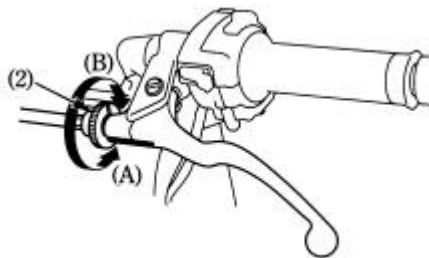
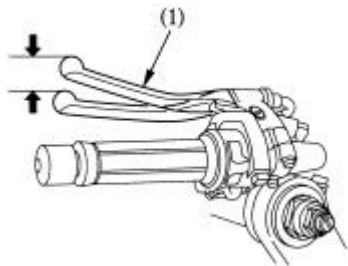

(2)

(A)

(B)

가

(1)

()

3. (66) 가 가

4. (4) .

(3)

(4)

5.

6.

가

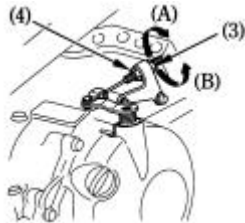

(3)

(A)

가

(4)

(B)

가

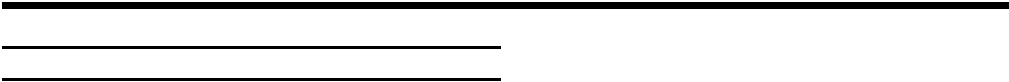

가 가 (50 50).

40%(40 60)
가
(60%).

()

- (1)
-
- (3)
- (4) (2)
-
-
-

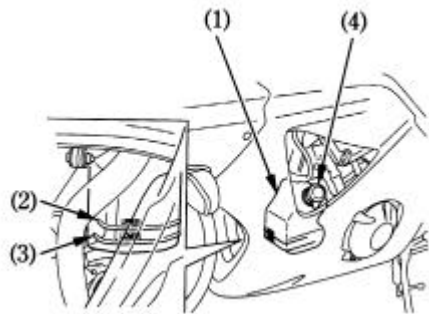

가

가 가

(1)
(3)

(2)
(4)

18.0

(1)

(2)

가

⚠경고

가

가

가

•

•

•

가

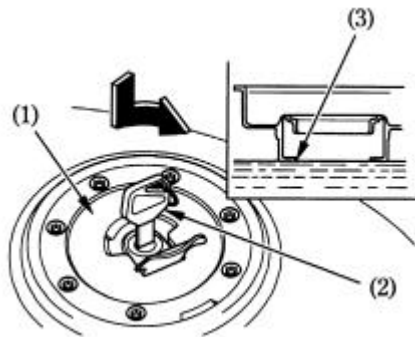

(1)
(2)

(3)

()

가가 91

가

가

가

가

()

(1)

(2)

(3)

1.

2.

3.

4.

5.

(1)

(2)

(93)

(4)

(1)

(2)

(3)

(4)

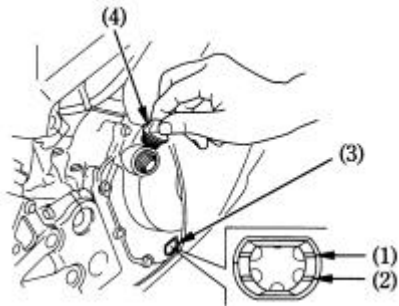

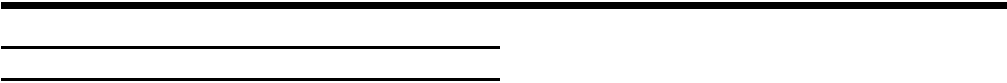

가 가 , ,
가 , .

, ,
가 가
가

가

가

, 1

가

가

()

km

가 가

3

. 가

	2.50 kgf/cm ²
	2.90 kgf/cm ²

•

•

•

가

가

	1.5 mm
	2.0 mm



(1)

(2)

()

24

80 km/h

130 km/h

가

가

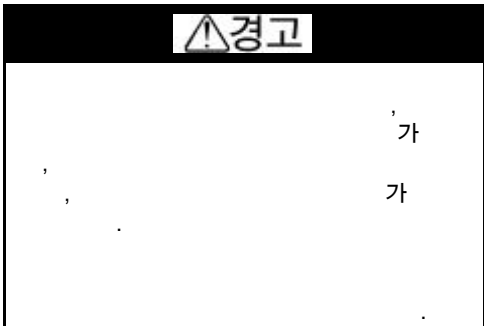

: 120/70 ZR17 (58W)
120/70 ZR17 M/C (58W)
BRIDGESTONE
BT012F RADIAL G
MICHELIN
Pilot SPORT E

: 190/50 ZR17 (73W)
190/50 ZR17 M/C (73W)
BRIDGESTONE
BT012F RADIAL G
MICHELIN
Pilot SPORT E

()

* 가

* 가

(1)

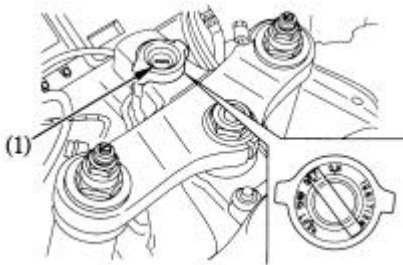

(1)

LOCK ()	가	
OFF	가	
ON	가	

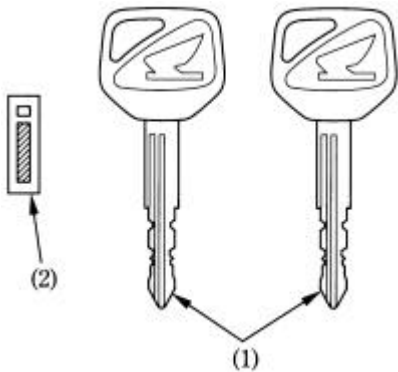
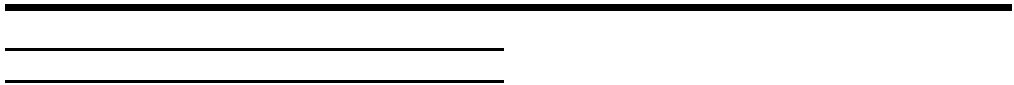

- (1)
- (2)

PGM - FI /

가

(HISS)

가

가

(HISS)

가

4

•

•

•

(HISS)

HISS
Security System)

(Honda Ignition

 (RUN)

ON

(HISS)

가

가

(HISS)

가
()

가

ON OFF

가 24 (HISS) 5

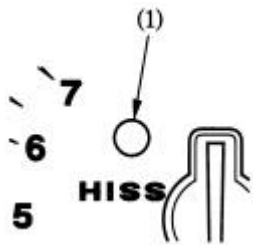

(1)

(HISS)

1. ON

2.

가

3. 10

OFF

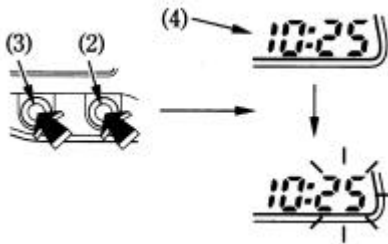

(2)

(3)

(4)

:

EC

R&TTE[,

(Radio equipment and telecommunications terminal equipment and the mutual recognition of their conformity)]

- 가
- 가
- 가

CE 0891 !

- (HISS)
- 가

R&TTE

- 가
- PGM - FI
- /



(1)
가 ○ (RUN)

가 ⊗ (OFF)

가
가 ⊗ (OFF)
가

(2)

(1)

72

○ (RUN)

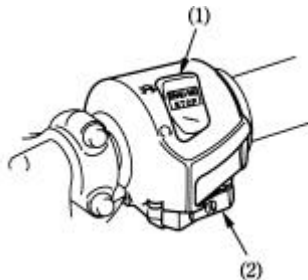

(1)

(2)

(1) 3 가
 (1) ☀, EDC, OFF()



EDC

OFF()

(2)



(HI)
 (LO)

(3)

가

가

(4)



(5)

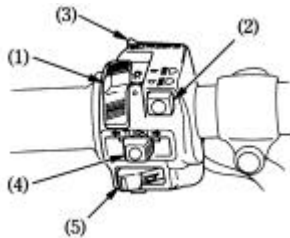

- (1)
- (2)
- (3)
- (4)
- (5)

(1) LOCK
OFF

경고

LOCK
가

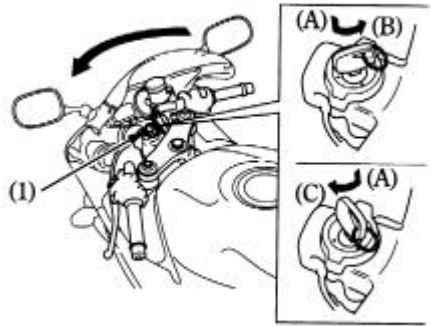

- (1)
- (A)
- (B) LOCK
- (C) OFF

()

(1)

(2) 2

(3)

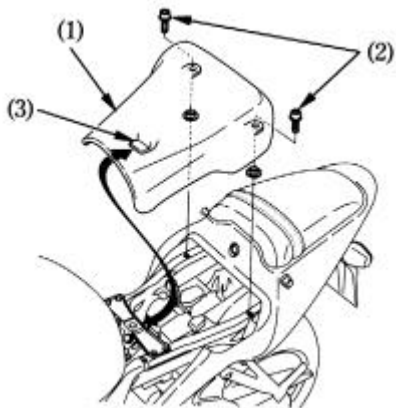

(1)

(2)

(3)

(4)

(5)

(6)



*

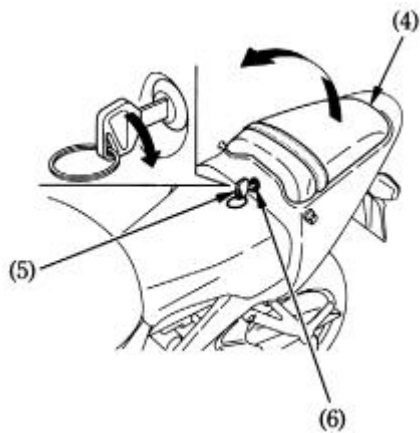

(4)

(5)

(6)

()

(1) (61).

(2)

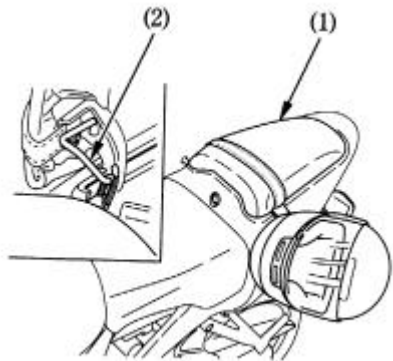
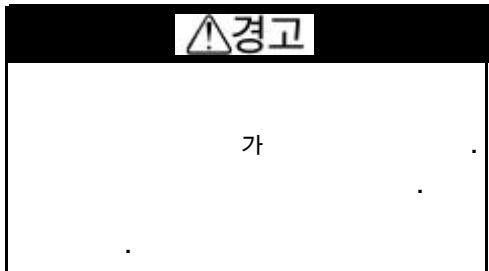

(1)
(2)

(1)

(3)

(2)

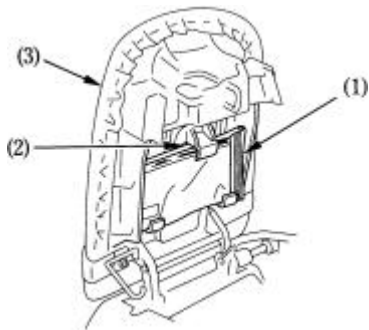

(1)
(2)

(3)

(4)

가

3.0 kg

(5)

가

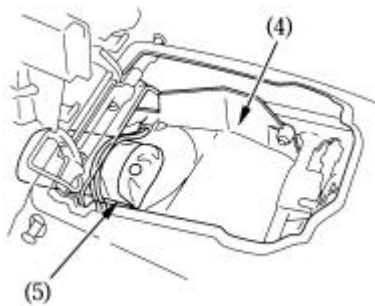

(4)

(5)

()

U

U

가

(1)

U

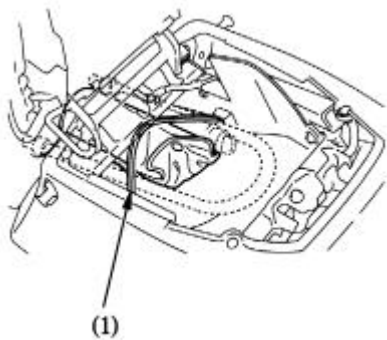

(1)

- 1.
- 2. (2)
- 3. (3)
- 4. (4) (5)

•

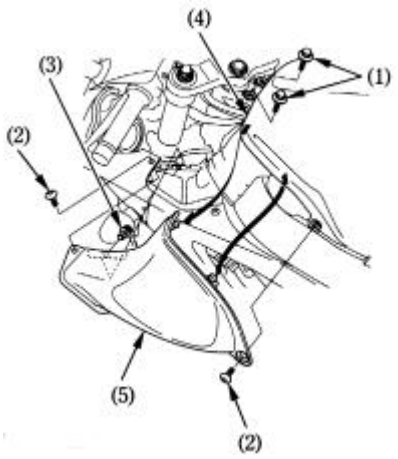

- (1)
- (2) (3)
- (4) (5)

()

1. _____ (65).
2. A (1) B(2)
3. A (3), B(4), C(5)
-
-

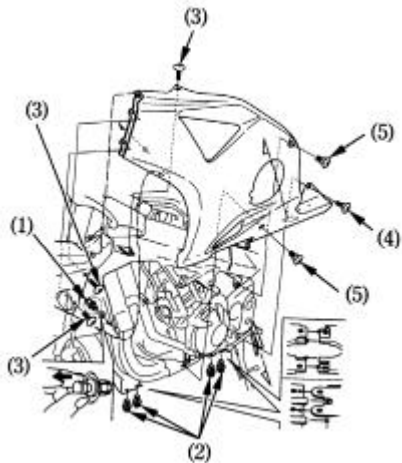

- | | | | |
|-----|---|-----|---|
| (1) | A | (3) | A |
| (2) | B | (4) | B |
| | | (5) | C |

-
-
-
1. (60).
 2. (65).
 3. (2) (1)
 4. (3) (3) (4)

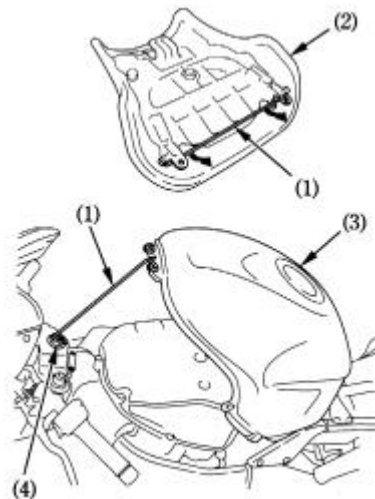

- (1) (2)
- (3) (4)

()

(1)

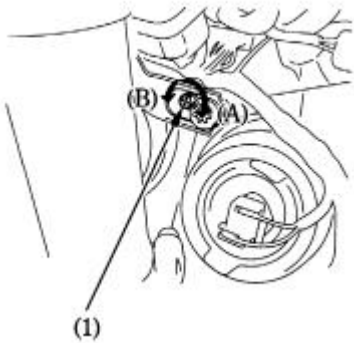

- (1)
- (A)
- (B)

1. -

(44).

2. -

(41).

3. -

(39~40)

4. -

(34~36).

 경고

가

가

가

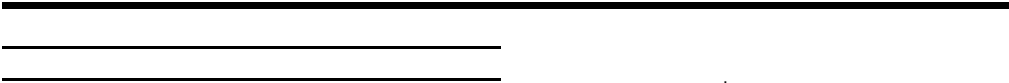

가

가

가

가

가

가

가

가

가

가

1

5

10

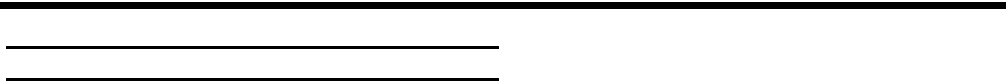

ON

가

-
-
-
-
-
-

(
○(RUN)

ON)

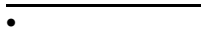

PGM - FI

:

(HISS)

(
).





500 km

.
가 .

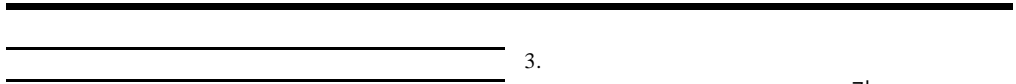

3.

(1-7)

가

113
)

(86

4.

가

가

2

3 , 4 , 5 , 6 ()

가

1.

가

2.

1 ()

5.

6.

가

가

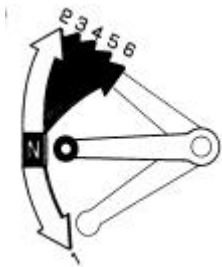

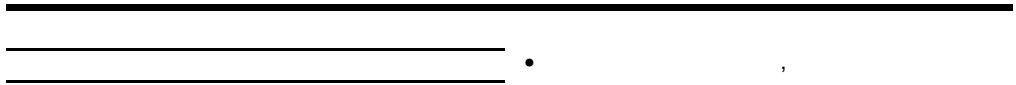

•

,

.

가

,

가

가

•

가

가

•

가

•

•

가

•

가

가

가

가

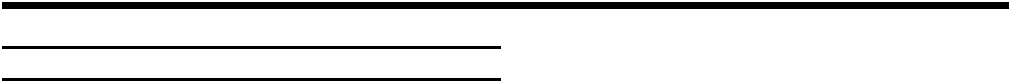

1.

OFF

2.

3.

(59).

1.

가

2.

가

3.가

가

4.

가

5.

가



⚠ 경고

가

가

가

가

가

가 가

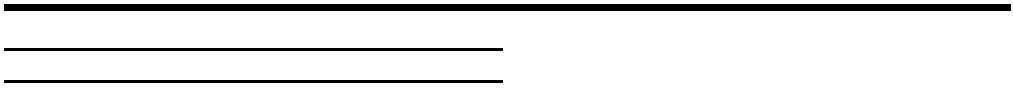

•

•

• 가

• 가

가

•

•

가

•

1

1,000km)

1 (

가

“ ”

가

가

“ ”

순정부품 마크

HONDA

GENUINE PARTS
Honda Motor Co., Ltd.
Made In Japan

1 6, 12
(1,000km)

가

87~88

가

) . (

,

.

가

I: , ,
C: R: A: L:

• 가

••

:
(1) 가 가
(2) 가 가
(3) 2 가

항목	주기	일찍 도래 하는 시기 ↓ 주	→ 적산 거리계 기록 [주 (1)]								참조 페이지										
			× 1,000 km	1	6	12	18	24	30	36											
			× 1,000 mi	0.6	4	8	12	16	20	24											
			원																		
● 연료 라인						I			I				I								-
● 스톱클 작동								I				I									102
● 에어 필터너		주 (2)							I												92
● 점화 플러그																					97
																					EVERY 24,000 km (16,000 mi) L, EVERY 48,000 km (32,000 mi) R
● 벨트 간극																					-
● 엔진 오일								R					R								93
● 엔진 오일 필터								R					R								94
● 엔진 아이들링 회전수								I	I	I	I	I	I	I	I	I	I	I	I	I	103
● 라디에이터 냉각수		주 (3)																			40
● 냉각 장치																					-
● 2차 에어 공급 장치 시스템																					-

항목	주기	일찍 도래 하는 시기 ↓ 주	적산 거리계 기록 [주 (1)]								참조 페이지																	
			→																									
			× 1,000 km	1	6	12	18	24	30	36		× 1,000 mi	0.6	4	8	12	16	20	24									
드라이브 체인																					I, L EVERY 1,000km (600mi)	105						
드라이브 체인 슬라이더																					I	111						
브레이크액		주 (3)																			I	I	R	I	I	R	34	
브레이크 패드 마모																					I	I	I	I	I	I	119	
브레이크 시스템																					I					I	34	
● 브레이크등 스위치																										I	-	
● 헤드라이트 변환																										I	-	
클러치 시스템																					I	I	I	I	I	I	I	37
●● 배기 밸브 제어 케이블																										EVERY 24,000km (16,000mi)	I	-
사이드 스탠드																										I	113	
● 서스펜션																										I	112	
● 너트, 볼트, 조임쇠																					I	I	I	I	I	I	I	-
●● 휠/타이어																										I	-	
●● 렌들 헤드 베어링																					I	I	I	I	I	I	I	-

(1)

(61)

-
- 10 X 12 mm
- 22 mm
- 32 mm
- 10 X 12 mm
- 12 X 14 mm
- 8 mm
- No. 2
- No. 2

-
-
-
-

- 5 mm
- 8 mm

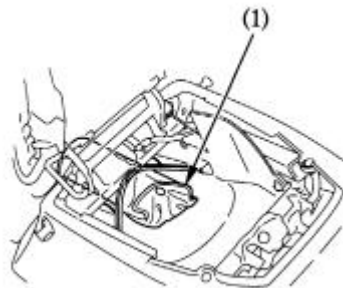

(1)

가 . 가 .



(1)

(1)

(2)

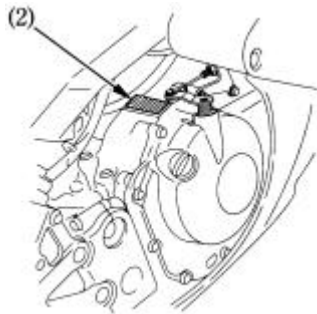

(2)

(1)

(61).

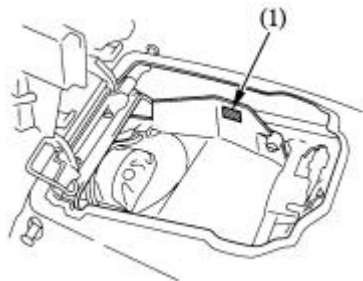

(1)

3.

(3)

(87).

가
가

가

(4)

가

1.

(67).

4.

2.

(2)

(1)

5.

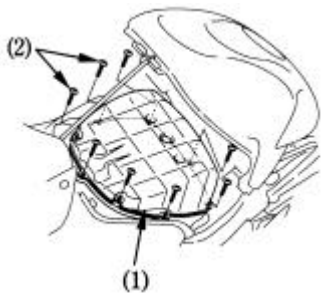

(1)

(2)

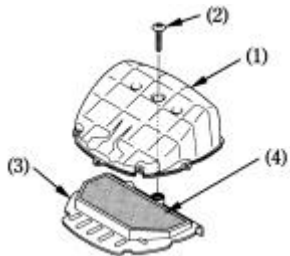

(3)

(4)

(82)

가
. API SG, SJ

가 가

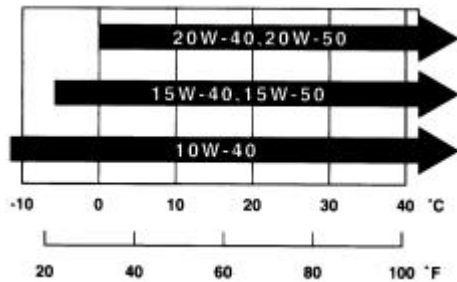

가

(87).

가

가



-
1. (66). 3. (3)
2. (1) (2)

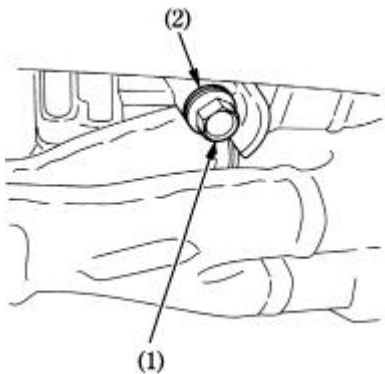

- (1) (2)

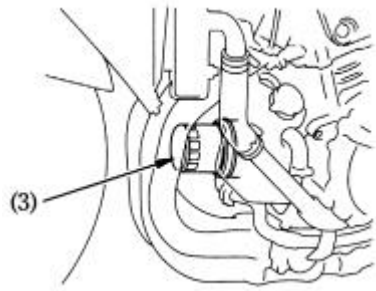

- (3)

4.

(4)

6.

2

5.

2.7 kgf·m

3.0 kgf·m

7.

3.7

8.

9.

2~3

10.

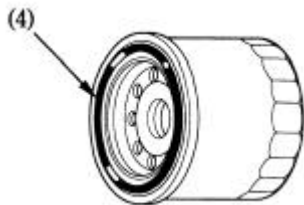

(4)

IMR9C-9H (NGK)

*

VUH27D (DENSO)

(5 , 41)

IMR8C-9H (NGK)

VUH24D (DENSO)

*



가가

*

-
1. (66)
 2. (1)
 3. (2) (3)
 4. (4)

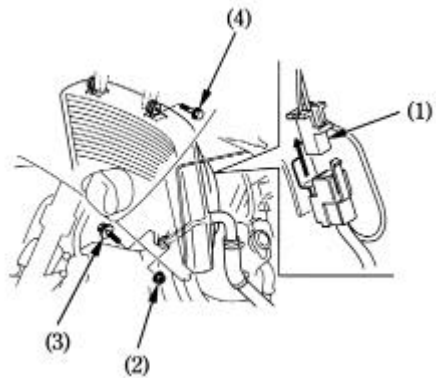

- (1)
- (2)
- (3)
- (4)

5. (5) (7)
 (8)
 6.

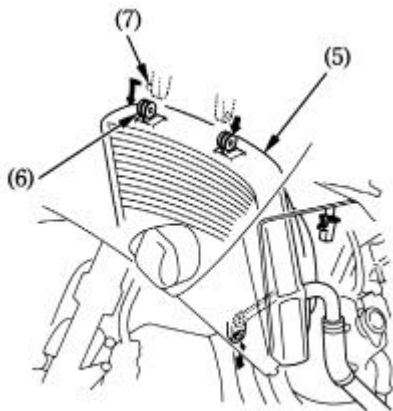

- (5)
 (6) (7)

7. (8)
 8. (9)

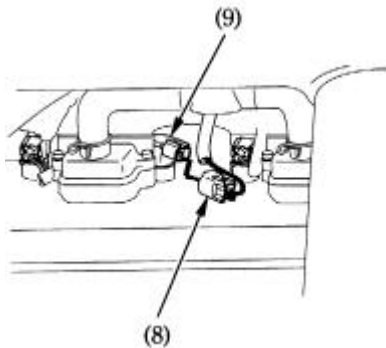

- (8)
 (9)

9.

(10)

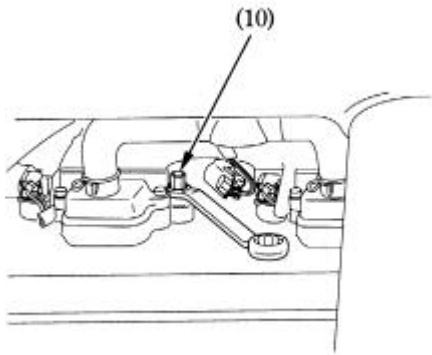

(10)

100

10.

가

11.

(11) 1.0 mm

가

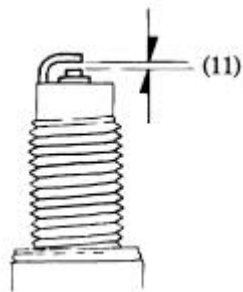

(11)

12.

가

15.

13.

16.

14.

17.

$\frac{1}{2}$

가

$\frac{1}{8} - \frac{1}{4}$



가

(82)

1.

2.

2 - 6 mm

(2)

(1)

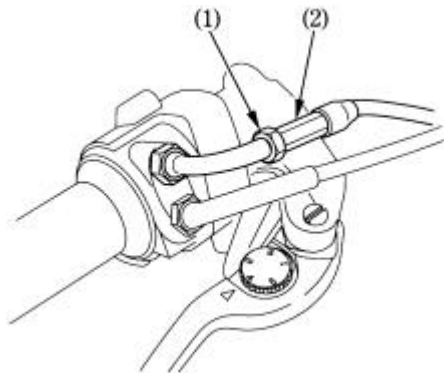

(1)

(2)

(82)

10

1.

2. (1)

():
 $1,200 \pm 100 \text{ min}^{-1} \text{ (rpm)}$

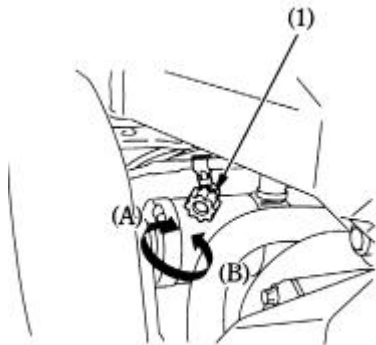

(1)

(A) 가
(B)

82

가

 경고

가

가

가

82

3.

가

(69)

1.

2.

가 40 - 50 mm 가

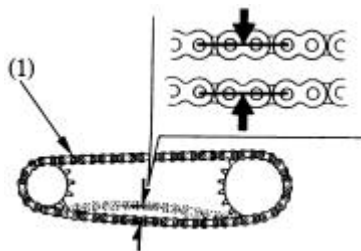

(1)

4.

가

손상된 스프로킷
교환

마모된 스프로킷 톱니
교환

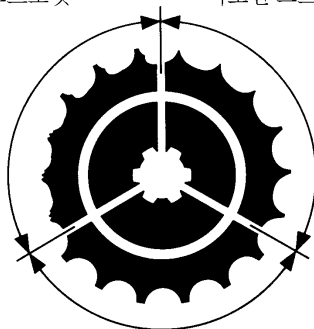

*
*
*
*
*
*
* O
*
*

가

O

1,000 km

가

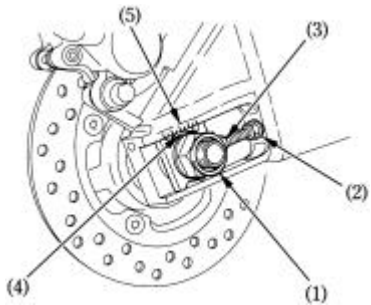

1.

2.

3.

4.

(1)

(3)

(3)

OFF

(2)

40 - 50 mm

(1)

(2)

(3)

(4)

(5)



(5) (4)

가

5.

: 11.5 kgf · m

가

6.

가

7.



(1)

40 - 50 mm

DID 50VA8 C1
RK GB50HFOZ5

50mm

master link)

(staking)

(2)가

(staked

가 (6)

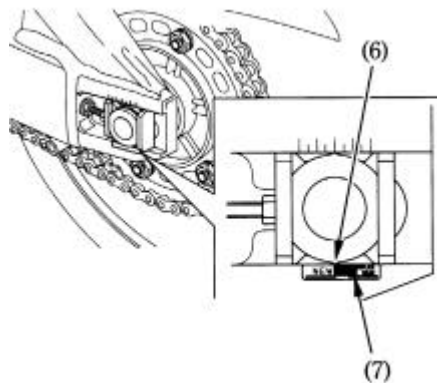

(7)

1,000 km



○

○

○

SAE 80

90

○

가

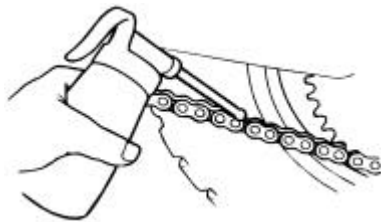

(82)

(1)

(2)

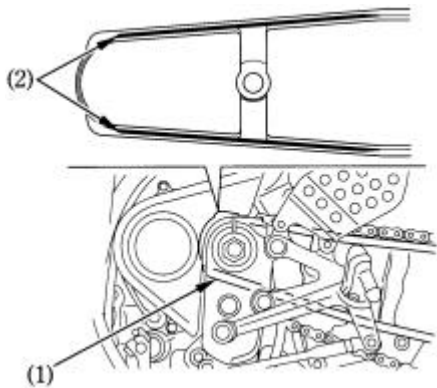

(1)

(2)

(82)

1.

2.

3.

(82)

• (1)

•
1.

2.

3.

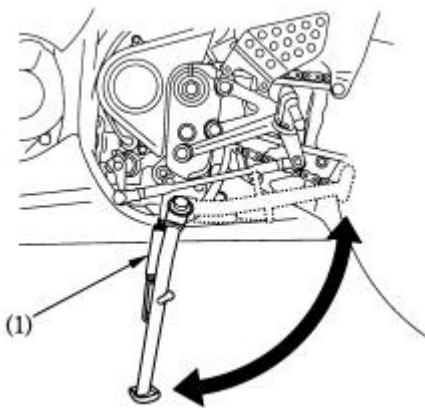

(1)

(82)

가

1.

2. (2) (Fork
leg) (caliper) (1)

가

(1)

(2)

가

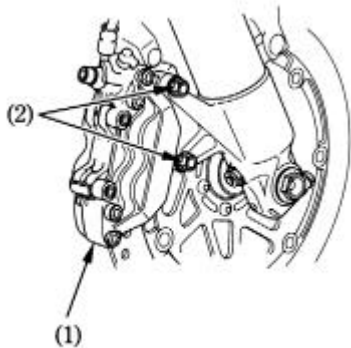

:

가

가

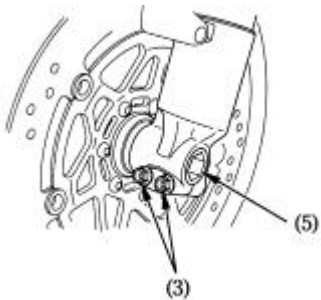

3. (3)

(5)

4. (4)

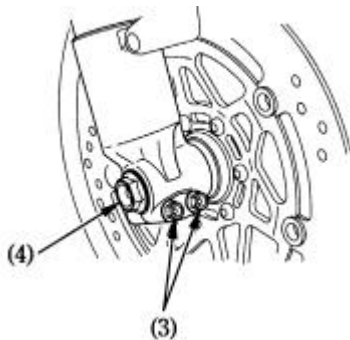

(4)

(3)

(5)

1.

2.

(6)

(7)

3.

: 2.2 kgf · m

4.

: 8.0 kgf · m

5.

: 3.1 kgf · m

가

6.

가

7.

: 2.2 kgf · m

, 가

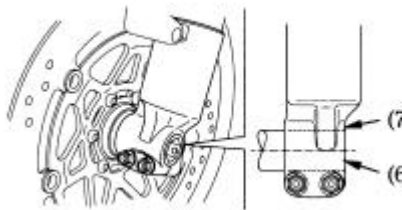

(1)

(2)

1.

2.

3.

4.

5.

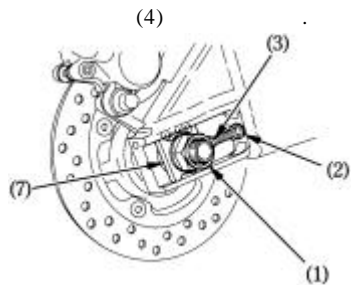

(1)

(2)

(3)

(4)

6.

(6),
(collar)

(5),

(7),

:

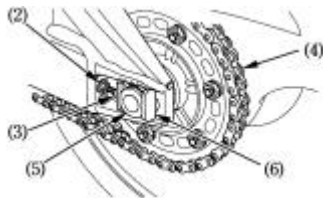

(5)

(6)

(7)

-
- (9) (8)
- (10)

-
- : 11.5 kgf · m
-

(90).



가

가

가

가

⚠ 경고

,가

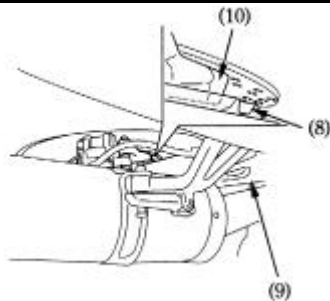

(8)
(10)

(9)

(82)

< >

가 가
) (88)

(1)

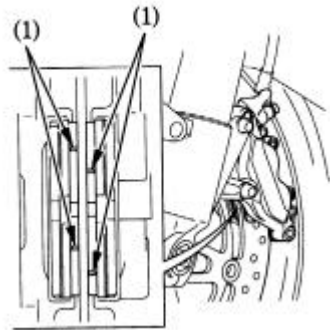

(1)

(2)

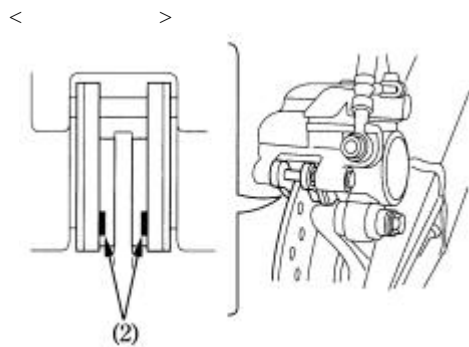

(2)

82

) (.
가 (.
) .



가 .

 경고

가 가

-
1. (60).
 2. (1)
 3. (-) (2)
 - (+) (3)
 4. (4)

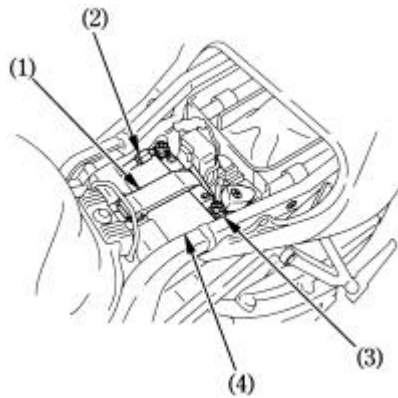

- (1)
- (2)
- (3)
- (4)

(82)

가

가



가

가

가

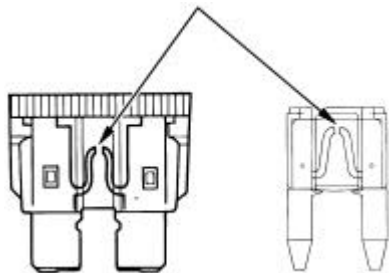

10A, 20A

1. (60).
2. (1)
- 3.
4. (2)

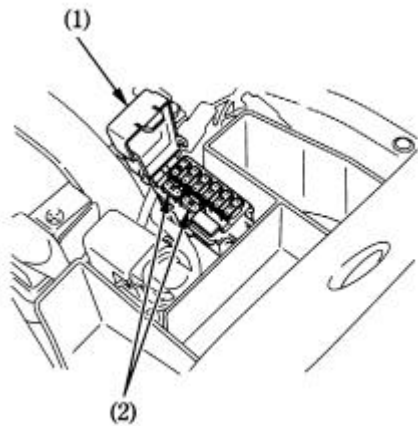

- (1)
- (2)

(1)

30A

(60).

1.

2.

3.

(3)

4.

(2)

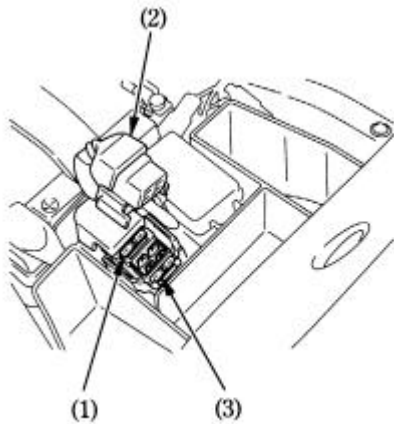

(1)

(2)

(3)

(82)

(1) (2) 가 가 (A)
(B) , 가

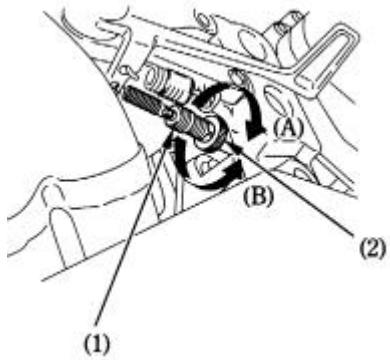

(1)
(2)

(82)

*

OFF

가

*

가

가

*

가

1. (1)
 2. (2)
 3. (3)
 4. (4)
 - 5.
- *

(5)

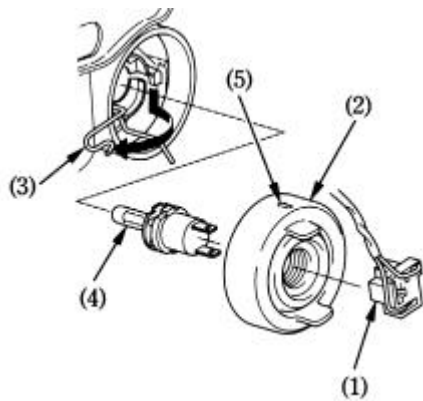

- (1)
- (2)
- (5)

- (3)
- (4)

-
1. (1)
 2. (2)
 - 3.

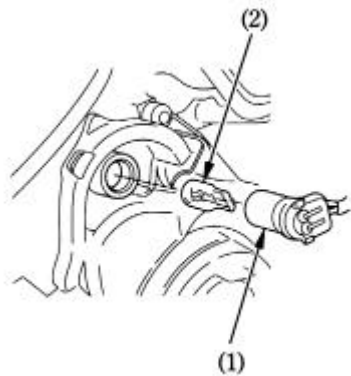

- (1)
- (2)

-
- /
1. (2)
 2. (2)
 3. (2)

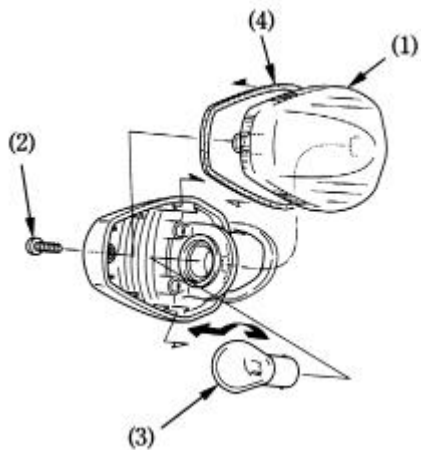

- | | |
|-----|-----|
| (1) | (3) |
| (2) | (4) |

/
LED가

LED

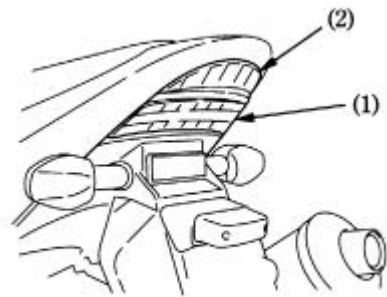

(1)
(2)

1. (2)

2. (3)

3.

(1)

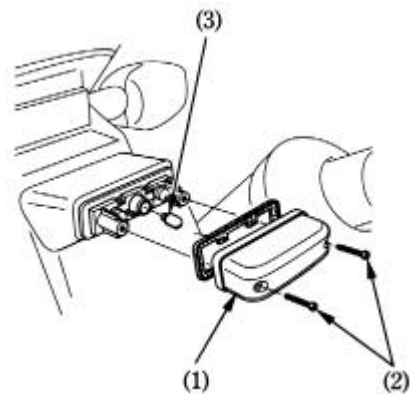

(1)

(3)

(2)

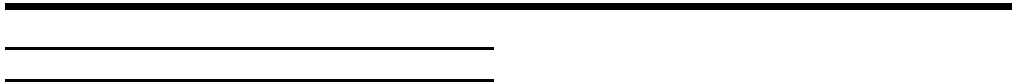

1.

2.

3.

가

가



()

()

4.

가

5.

6.

(touch up)

가

(59)



， ，

가

1. (133).

2.

가

가

가

가



가

*

*

*

1.

2. 50 50

3.

4.

•

•

•

•

•

(15 - 20 cm³)

5.

1

6.

7.

(110)

8.

가

9.

(

)

가

가

1.

4

2.

3.

4.

.(69)

		2,025 mm 680 mm 1,135 mm 1,400 mm
		168 kg
		3.5 3.7 4.0
		18.0 3.0 189 kg
		1

		75.0 54 mm
		11.5 : 1
		954 cm ³
		IMR9C - 9H (NGK) or VUH27D (DENSO)
	(5)	IMR8C - 9H (NGK) or VUH24D (DENSO)
		1,200 ± 100min - 1 (rpm)
	()	0.16 mm 0.27 mm

		23 ° 45' 97 mm 120/70 ZR17 (58W) 190/50 ZR17 (73W)
	1	1.520
	1	2.692
	2	1.933
	3	1.600
	4	1.400
	5	1.285
	6	1.190
		2.687

		12 V - 8.6 AH
		0.421 kW/5,000 min ⁻¹ (rpm)
		12V – 55 W
	/	LED
		12V – 21 W
		12V – 21 W
		12V – 5 W
		30 A
		10 A, 20 A



제작 결함 사항 보고

제작사 : 혼다코리아 주식회사

주 소 : 서울시 강남구 대치동 945-10 KT&G 코스모대치타워 11F

연락처 : 02-3416-3300 (대표번호)

제작 결함 사항에 관하여...

귀하의 자동차에 잦은 고장 등의 문제로 인하여 교통 사고를 유발 할 수 있는 안전도 관련 결함 등이 있다고 판단되면, 귀하는 자신 및 다른 사람의 안전을 위하여 즉시 혼다 코리아(주)와 국토해양부에 연락해 주시기 바랍니다. 국토해양부는 소비자 불만사항 등을 접수하여 분석한 후 해당 사항이 제작결함 가능성이 있다고 판단되는 경우 제작결함 조사를 실시하여 해당 제작사에게 제작결함 시정(Recall)등의 조치를 취할 것입니다.

소비자 불만 접수(자동차 결함 신고)등의 창구는 다음과 같습니다.

자동차 결함 신고 센터

- 제작 결함 신고 전용 전화: 080-357-2500
- 인터넷 홈페이지: www.car.go.kr

본 차량에 대한 문의·상담은 혼다 판매점이나 전국 공통
무료전화로 아래의 고객 상담센터에서 받고 있습니다.

080-322-3300

혼다코리아(주) 고객 상담센터

접수시간 09:30-18:00

135-846 서울시 강남구 대치동 945-10 번지 KT&G 코스모대치타워 11F
소재지, 전화번호가 변경될 수 있으므로 양지하시기 바랍니다.

본 저작물의 한국어판 저작권은 혼다 코리아(주)가 소유합니다.
저작권법에 의하여 한국내에서 보호를 받는 저작물이므로 무단전재와 무단복제를 금합니다.

HONDA
The Power of Dreams